

Way Wipers



For long-life machine tool protection

KabelSchlepp's complete three-point seal

KabelSchlepp's way-wipers offer an exclusive three-point sealing system which ensures that your close-tolerance machine tool slideway receives all the protection it needs from hot chips, abrasives and cooling agents.

The tough polyurethane wiper blade is specially designed to seal against these wear-causing agents at three critical points:

- 1 Front lip of blade is suspended under tension to provide a tight seal on the machine slideway.
- 2 The rear lip gives additional protection for both directions of machine travel.
- 3 The unique top lip seals the moving part of the machine preventing harmful material from seepage between wiper and machine from above.

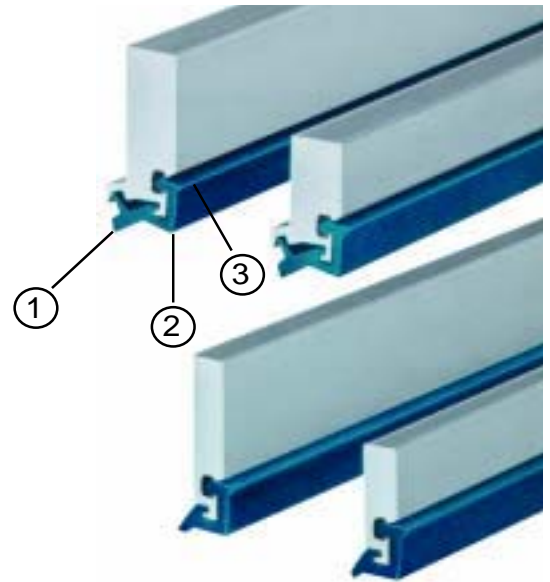

Other important features:

- Four types and sizes are available - two with frame overhang to protect the blade from hot chips.
- Solid aluminum alloy frame - lightweight and non-corrosive.
- Mounting holes are drilled through the frame only, which in turn ensures that there is no distortion to the wiper blade.
- Blade elements are easily replaceable.
- Optional copper alloy chip shields can be added for complete protection of wiper blades from hot chips.

Versatile wiper types and sizes

Type BA18 & 25

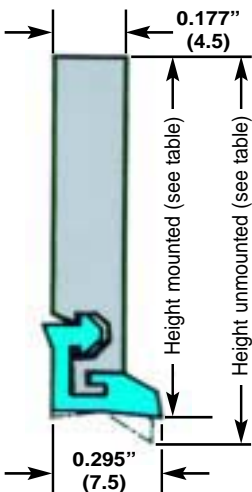

When ordering, please specify type and size (e.g. BA25, BAS25). Optional copper alloy hot-chip shields available for Type BAS

Type BAS18, 25 & 40

(Available with hot chip shields)

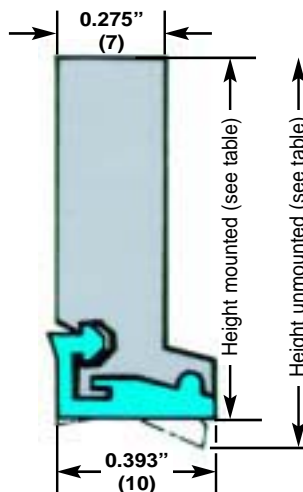

Table of heights

Order No.	Unmounted height	Mounted height
BA18	0.708" (18mm)	0.669" (17mm)
BA25	0.944" (24mm)	0.905" (23mm)
BAS 18	0.708" (18mm)	0.669" (17mm)
BAS25	0.944" (24mm)	0.905" (23mm)
BAS40	1.575" (40mm)	1.535" (39mm)

Order pre-assembled way-wipers



KabelSchlepp way-wipers can be ordered pre-assembled to your exact specifications. Just send us a drawing of the slideway and moving part of the machine and we'll cut and assemble the wiper to any

configuration - right angle, U or V-shape, dovetail, prismatic - all standard and special slideway shapes. All you need to do is mount the finished custom fit wipers on your machine.

Cut and assemble to your needs

KabelSchlepp provides convenient 39.4" stock lengths for economical and fast in-plant assembly.

Cut and assemble your own wiper following the easy four step installation procedure, reducing ordering time and eliminating the fabrication cost.

Easy four step installation

- 1. Measuring** - Simply order stock lengths and measure slideway to be protected.
- 2. Cutting** - Lightweight Aluminum alloy frame with wiper blade in place is easily cut to required lengths and angles.
- 3. Pinning** - Drill two holes through each angle.
- 4. Mounting** - Drill holes through the metal frame and drill and tap the moving part of the machine. Attach the wiper to the machine.

Optional hot-chip shield

For additional protection from hot chips, KabelSchlepp offers a pre-formed copper alloy strip for use with Type BAS that can be attached with mounting screws. The hot chip shield

provides complete protection for the wiper blade from hot chips and will not scratch the slideway surface.



Economical and easy to install for the machine tool builder or end user. KabelSchlepp way-wipers offer complete slideway protection for original equipment or retrofit applications.

Specifications:

- Length:** Standard length of 39.4" (1000mm).
- Height:** 0.669" (17mm), 0.905" (23mm), and 1.535" (39mm) mounted.
- Frame:** Solid, non-corrosive aluminum alloy. Type BAS protects wiper blade from hot chips.
- Blade:** Polyurethane. Long wearing and resistant to oil, cooling agents, most chemicals. Will withstand temperatures up to 200° F.
- Tension:** 0.0394" (1mm).