

# MF2C ROTARY LIMIT SWITCH

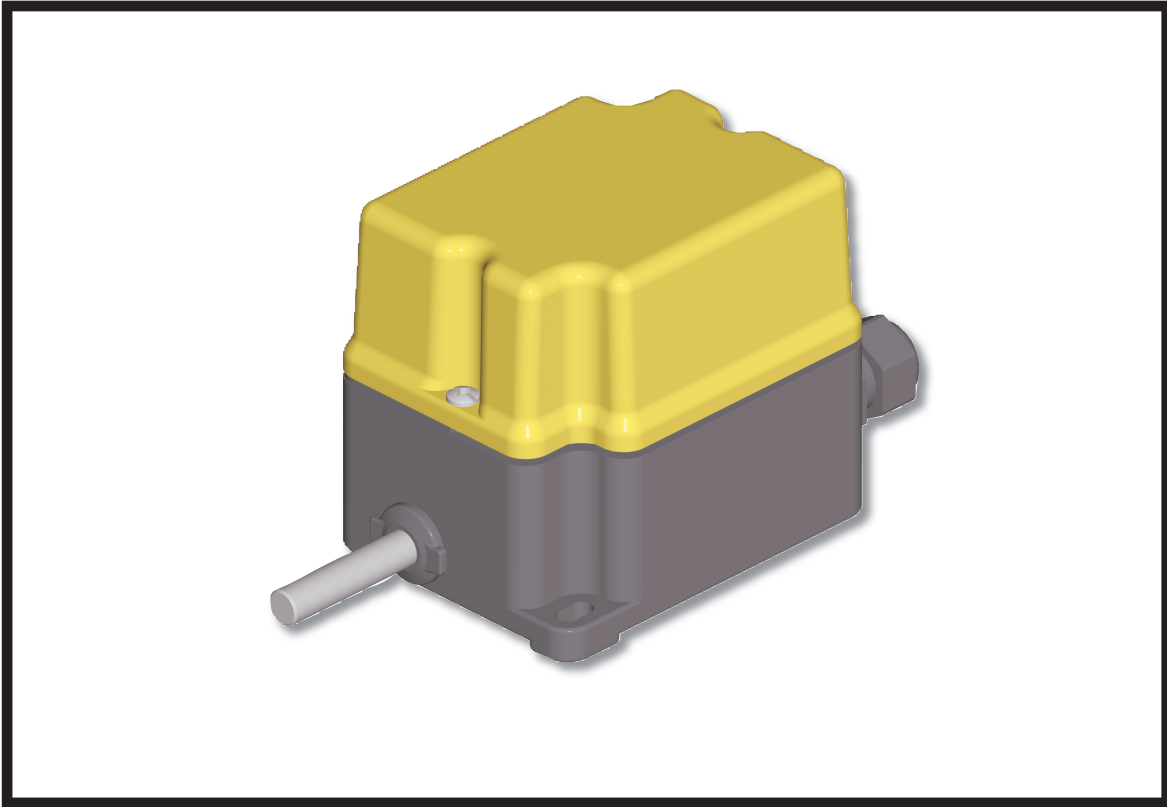

— The rotary limit switch is used to control the movement of industrial machinery. It operates as an auxiliary controller of electrical motors through a power interface, such as a contactor or PLC. Suitable for heavy duty, its shaft is connected to the motor and, after a set number of revolutions, the cams operate the switches, thus starting the predetermined movement.

— A worm gear and a helical toothed gear combined with one or more pairs of straight toothed gears are used for the transmission of the movement from the input shaft to the output shaft. Revolution ratios ranging from 1:1 to 1:150 result from the use of different combinations of gear wheels between the input shaft and the output shaft, which is connected to the cams operating the switches.

— Overall dimensions are suitable for assembly in small spaces. Transmission and gear driving shafts are made of stainless steel to prevent oxidation and wear. The gear wheels and the driving bushes are made of self-lubricating thermoplastic material, suitably chosen to reduce the wear to a minimum and to maintain the accuracy of the couplings over time. Sintered bronze bushes are moulded into the base of the limit switch to optimise the shaft rotation and to prevent rubbing with plastic material.

— Each cam can be set with great accuracy thanks to the cam adjusting screws. The auxiliary switches are of the positive opening type, thus suitable for safety functions. The limit switch is available with direct control switches for operating directly on the motor.

— Materials and components are wear resistant and protect the equipment against water and dust. The limit switch can be customised with labels and colours according to the customer's requirements.

# MF2C ROTARY LIMIT SWITCH

## TECHNICAL SPECIFICATIONS

Conformity to Community Directives	73/23/CEE	93/68/CEE
Conformity to Standards	EN 60204-1	EN 60947-1 EN60947-5-1 EN 60529 EN 50013 IEC 536
Ambient temperature	Storage	-40°C/+70°C
	Operational	-25°C/+70°C
Protection degree	IP 65	
Insulation category	Class II	
Cable entry	Cable clamp M16	
Homologations	CE (UL - (c)UL limit switches available on request)	

## TECHNICAL SPECIFICATIONS OF THE SWITCHES

Utilisation category	AC 15
Rated operational current	3 A
Rated operational voltage	250 V
Rated thermal current	10 A
Rated insulation voltage	300 V~
Mechanical life	1x10 <sup>6</sup> operations
Terminal referencing	According to EN 50013
Connections	6.3 mm Faston taps
Homologations	CE - UL - (c)UL

## STANDARD LIMIT SWITCH CODES

REVOLUTION RATIO	2 SWITCHES	3 SWITCHES
1:15	PF0901 0015 0003	PF0901 0015 0004
1:25	PF0901 0025 0005	PF0901 0025 0006
1:50	PF0901 0050 0005	PF0901 0050 0012
1:75	PF0901 0075 0004	PF0901 0075 0005
1:100	PF0901 0100 0005	PF0901 0100 0007
1:150	PF0901 0150 0003	PF0901 0150 0004

Standard limit switches are equipped with 2 or 3 snap action switches and with pointed cams PRSL7140PI. Other assemblies and revolution ratios are available on request. Maximum revolution ratio 1:150.

## OVERALL DIMENSIONS

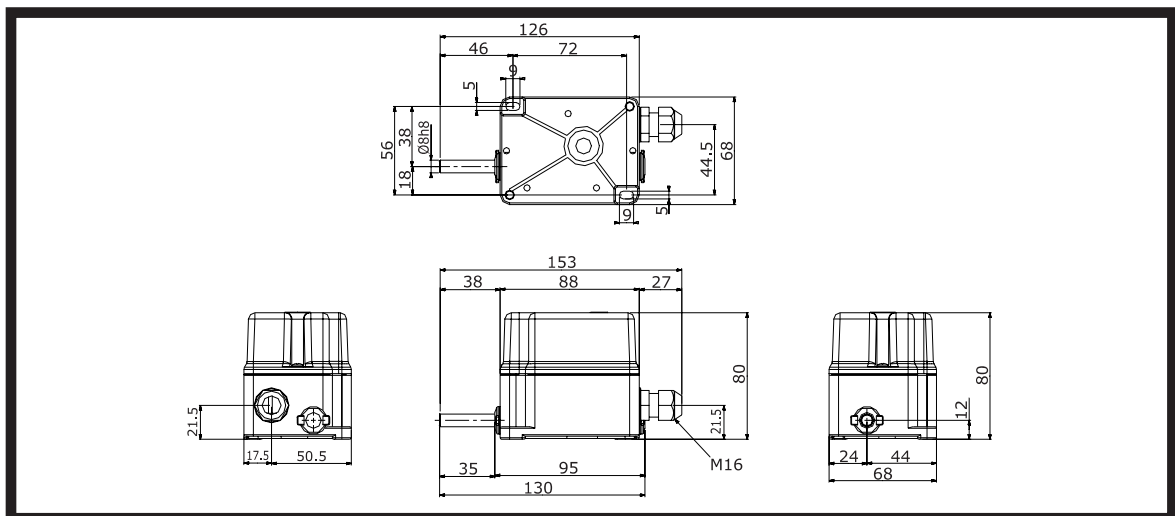

ENERGY SOLUTIONS FOR CRANES, HOISTS & MONORAILS

Toll Free: 1.888.822.2024

International: +1.519.822.2020

Fax: 1.519.822.2140

Email: info@ipandc.com

Web: www.ipandc.com

# MF2C ROTARY LIMIT SWITCH

DETAILED DRAWING

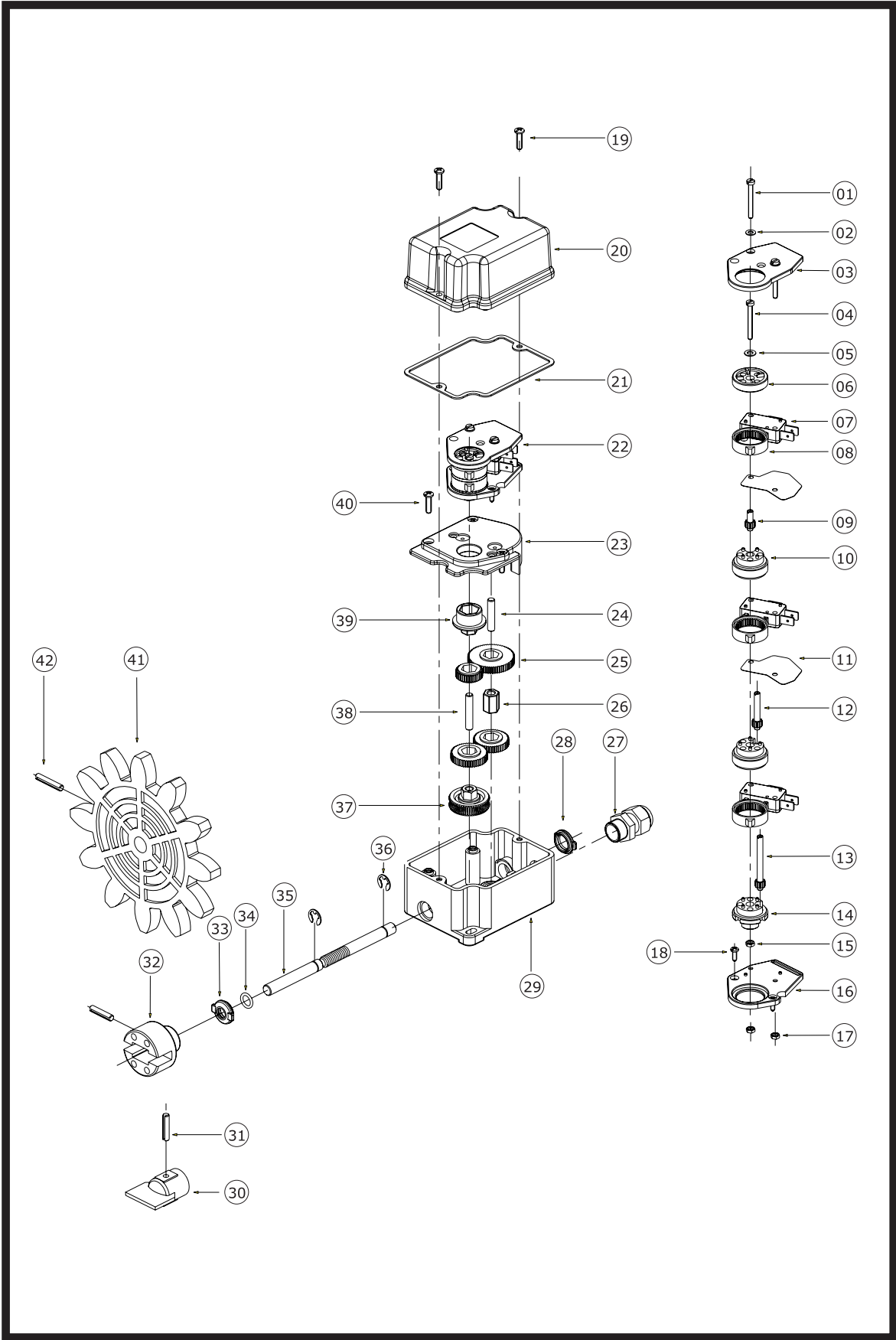









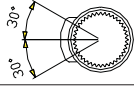
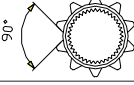
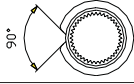

MF2C ROTARY LIMIT SWITCH

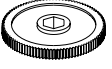

# MF2C ROTARY LIMIT SWITCH

## SPARE PARTS

REFERENCE	DRAWING	CODE	DESCRIPTION
07		PRSL0003XX	Snap action switch
08		PRSL7140PI	Pointed cam
08		PRSL7141PI	Sector cam
08		PRSL7142PI	10 point cam
08		PRSL7143PI	Circular cam
08		PRSL7144PI	180° cam
25		PRSL6600PI	Lateral gear wheel Z 36
		PRSL6601PI	Lateral gear wheel Z 38
		PRSL6602PI	Lateral gear wheel Z 40
		PRSL6603PI	Lateral gear wheel Z 42
		PRSL6604PI	Lateral gear wheel Z 44
		PRSL6605PI	Lateral gear wheel Z 46
		PRSL6606PI	Lateral gear wheel Z 48
		PRSL6607PI	Lateral gear wheel Z 50
		PRSL6608PI	Lateral gear wheel Z 52
		PRSL6609PI	Lateral gear wheel Z 54
		PRSL6611PI	Lateral gear wheel Z 56
PRSL6612PI	Lateral gear wheel Z 58		
PRSL6613PI	Lateral gear wheel Z 60		
PRSL6614PI	Lateral gear wheel Z 62		
PRSL6615PI	Lateral gear wheel Z 64		
30 +31		PRSL0919PI	Male coupling
32 +31		PRSL0920PI	Female coupling
35		PRT00063PE	Single-thread worm shaft
35		PRT00075PE	Flexible shaft
37		PRSL6701PI	Central gear wheel Z 50
41 +42		PRSL0911PI	Pinion gear M10 Z12
		PRSL0912PI	Pinion gear M12 Z10
		PRSL0913PI	Pinion gear M14 Z10
		PRSL0914PI	Pinion gear M16 Z10
		PRSL0915PI	Pinion gear M20 Z8
		PRSL0916PI	Pinion gear M5 Z12
		PRSL0917PI	Pinion gear M6 Z11
		PRSL0918PI	Pinion gear M8 Z12
		PRSL0944PI	Pinion gear M12 Z12

MF2C ROTARY LIMIT SWITCH





# MF2C ROTARY LIMIT SWITCH

## USE AND MAINTENANCE INSTRUCTIONS

*The MF2C rotary limit switch is an electromechanical device for low voltage control circuits (EN 60947-1, EN 60947-5-1) to be used as electrical equipment on machines (EN 60204-1) in compliance with the fundamental requirements of the Low Voltage Directive 73/23/CEE and of the Machine Directive 89/392/CEE.*

The limit switch is designed for industrial use and also for use under particularly severe climatic conditions (operational temperature from  $-25^{\circ}\text{C}$  to  $+70^{\circ}\text{C}$ , suitable for use in tropical environment). The equipment is not suitable for use in environments with potentially explosive atmosphere, corrosive agents or a high percentage of sodium chloride (saline fog). Oils, acids or solvents may damage the equipment. Use the fixing holes on the base (29) to mount the limit switch. The use of special couplings (30, 32), flexible shafts or special driving systems (not supplied) are recommended for eliminating any misalignment between the limit switch shaft (35) and the reduction gear shaft to which it is connected. After loosening the central screw (04) use the screws (09, 12, 13) to adjust the operating point of the cams (08); once the cams are adjusted, tighten the central screw (04).

The switches (07) are designed for auxiliary control of contactors or electromagnetic loads (utilisation category AC-15 according to EN 60947-5-1). The switches (07) have positive opening operation contacts (EN 60947-5-1). Do not connect more than one phase to each switch (07). Do not oil or grease the control elements (08) or the switches (07). For easy wiring, the set of cams-switches (22) may be removed by loosening the screws (18) on the lower fixing plate; do not loosen the screws on the upper part of the set of cams-switches (01) in order not to take apart the switches; after wiring is completed, the set of cams-switches (22) must be properly fixed and screwed, paying attention to the coupling of the hexagonal plastic bushes (14, 39).

The installation of the limit switch shall be carried out by an expert and trained personnel. Wiring shall be properly done according to the current instructions.

Prior to the installation and the maintenance of the limit switch, the main power of the machinery shall be turned off.

### Steps for the proper installation of the limit switch

- loosen the fixing screw (19) and remove the cover (20)
- connect the limit switch shaft (35) to the reduction gear shaft; to avoid any misalignment between the two shafts the use of couplings (30, 32), flexible shafts or special driving systems is recommended
- fix the limit switch firmly in place to prevent abnormal vibrations of the equipment during operation; use only the fixing holes on the base (29) to fix the equipment
- insert the cable into the limit switch through the cable clamp (27)
- strip the cable to a length suitable for wiring the switches (07)
- tape the stripped part of the cable
- clamp the wire into the cable clamp (27)
- connect all the switches (07) according to the contact scheme printed on the switches (use 6.3 mm Faston taps)
- adjust the operating point of the cams (08); for proper adjustment, loosen the central screw (04) of the cam set, adjust the operating point of each single cam (08) by turning its screw (09, 12, 13) (the numbers on the screws refer to the cams counting from bottom to top), then tighten the central screw (04)
- close the limit switch checking the proper positioning of the rubber (21) in the cover (20)

### Periodic maintenance steps

- check the proper tightening of the screws (19) and cover (20)
- check the proper tightening of the central screw (04) holding the cams
- check the wiring conditions (in particular where wires clamp into the switch)
- check the proper positioning of the front (33) and rear (28) bush covers
- check the conditions of the rubber (21) fit between the cover (20) and the base (29) and check the tightening of the cable clamp (27) around the cable
- check that the limit switch enclosure (20, 29) is not broken
- check the alignment between the limit switch shaft (35) and the reduction gear shaft
- check that the limit switch is properly fixed

In case any component of the limit switch is modified, the validity of the markings and the guarantee on the equipment are annulled. Should any component need replacement, use original spare parts only.

TER declines all responsibility for damages caused by the improper use or installation of the equipment.

